

CHALLENGE	SOLUTION	BENEFIT
Develop a cost-efficient infrastructure that provides a complete overview of data, secure and reliable operations, high scalability, and 24x7 availability	Intel® Pentium® III Xeon™ processor-based Dell™ PowerEdge™ 6450 servers, a Dell EMC FC4700 Fibre Channel storage array, and Oracle9™ Real Application Clusters software	Reliable traffic planning and an attractive price/performance ratio

Back on track

Using a Dell-Intel-Oracle solution, the Danish National Railway Agency stopped being the little railway that could and became the little railway that does

In Europe, railways are big business. Every day, European railways allow people and business freight to traverse the continent, and the state-owned railway in Denmark is no exception. After the 1997 breakup of Danske Stats Banen (Danish State Railway Authority), the government wanted to establish a new organization that would open up the Danish railroads to spirited competition, giving more freight companies access to the Danish market.

As more and more companies climbed onboard the Danish railroads, the Danish National Railway Agency discovered that it needed a more reliable, high-performance IT system to manage the increased traffic. In addition, the Danish National Railway Agency's many activities—managing railroad operations, maintenance, rail capacity, and train-freight tolls—became more expensive as traffic grew. Because trains on the Danish railways must run like clockwork, the Danish National Railway Agency decided to engineer a cost-effective solution that would keep its trains running on time.

Laying the tracks for the IT infrastructure

To begin the upgrade, the Danish National Railway Agency decided to replace its traffic planning system, which required manual coordination of train times based on data from various platforms and operators.

To help ensure that employees could keep the trains in sync, the Danish National Railway Agency chose P_Base, an application that provides a single point of access for traffic planning data. Railway coordination is a complicated production, and P_Base gives railway employees an instant, easily accessible overview of the traffic information they need to fulfill their roles.

Like airplanes, trains must depart on time to avoid sending a ripple of disruptions throughout the railway network. But if the

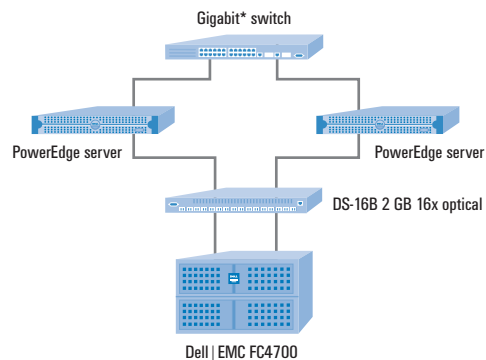

* Gigabit Ethernet indicates compliance with IEEE® 802.3ab and does not connote speeds of 1 Gbps

The Danish National Railway Agency uses Dell PowerEdge servers and Dell | EMC storage in a cluster configuration

“We had already decided four to five years ago to go with Dell as our hardware supplier. That means we have become quite competent on Dell systems.”

— **Kim Remmer**
IT Operations Manager
Danish National Railway Agency



P_Base application were to run on an unstable platform, Denmark’s trains could remain stuck in the stations. That’s why the Danish National Railway Agency carefully examined its hardware options.

Climbing onboard with Dell and Oracle

IT Operations Manager Kim Remmer oversees the team that runs the day-to-day system operations for the Danish National Railway Agency. He explains that the supplier, WM-data, would only guarantee the stability of the P_Base application on certain platforms—including Dell. Remmer says this requirement was right on track with the organization’s existing plans.

“We had already decided four to five years ago to go with Dell as our hardware supplier. That means we have become quite competent on Dell systems. Throughout all these years we have only had good experiences with Dell, and Dell delivers professional solutions that yield a high return on the investment.”

To meet its latest need, the Danish National Railway Agency chose Dell and Oracle and their partnership platform consisting of Intel® Pentium® III Xeon™ processor-based Dell™ PowerEdge™ servers and Oracle9i™ Real Application Clusters (RAC) software. Backed by this solution, the P_Base application provides top reliability and allows the Danish National Railway Agency to standardize its IT shop on Dell servers and Microsoft® Windows® operating systems.

The new IT infrastructure consists of two Intel processor-based Dell PowerEdge 6450¹ servers running Oracle9i RAC software, one 3Com® switch, and a storage area network (SAN). The SAN uses a Dell|EMC FC4700 Fibre Channel storage array.

Remmer says the Dell-Intel-Oracle system has helped the organization move from an outdated traffic planning system to a modern system that can grow in the future. “The cluster solution gives us various benefits,” Remmer says. “We load balance between the two servers, which yields greater stability and scala-

bility. The system now has two nodes and is scalable up to four, so there is plenty of room to grow over the next several years.”

Danish National Railway Agency CIO Kenneth Lau Rentius says another benefit is that the costs to purchase and maintain the solution created an attractive bottom line.

“The combination of Oracle and Dell on a Windows-based, Intel architecture platform is a supreme solution compared with many other technical alternatives and has given us a powerful system with a great price/performance ratio,” Lau Rentius says.

Dell configured, built, and tested the solution at the Dell customer center in Ireland. There, Dell specialists helped ensure that the system matched the quality and concise requirements outlined by the Danish National Railway Agency. After that, the installation at the Danish National Railway Agency was a smooth ride.

Gaining steam for the future

By providing a secure platform for the P_Base application, Dell, Intel, and Oracle have enabled the Danish National Railway Agency to run an efficient, cost-effective traffic planning system.

“From this experience, we have learned that both Dell and Oracle have a good understanding of our requirements,” Remmer says. “Our joint effort with these two companies has run without difficulty. Oracle assisted us with the final system configurations. Dell provided us with a system that was ready to run when it arrived. As a result, we did not need much assistance from Dell Copenhagen.”

FOR MORE INFORMATION

<http://www.dell.com/servers>

<http://www.dell.com/storage>

<http://www.intel.com/xeon>

¹ Newer models are available at <http://www.dell.com>.